



RIVKLE® P3007

Pneumatic power tool for controlled setting of large blind rivet nuts

- Powerful
- Robust construction



MeFaCo
INDUSTRIAL FASTENERS AND TOOLS

BOLLHOFF

RIVKLE® P3007 – Pneumatic power tool for controlled setting of blind rivet nuts

2 versions are available

■ RIVKLE® P3007 - 236 159 01 000

Dedicated to large diameters of RIVKLE® blind rivet nut



	ø RIVKLE®				
	M8	M10	M12	M14	M16
Steel	■	■	■	■	■
Stainless steel	■	■	■	■	■
Aluminium	■	■	■	■	■

■ RIVKLE® P3007 PN - 236 160 01 000

Dedicated to RIVKLE® Plusnut that require longer stroke



	ø RIVKLE® PN	
	M8	M10
Steel	■	■
Stainless steel	■	■

Technical data

Characteristics	RIVKLE® P3007	RIVKLE® P3007 PN
Setting capacity	RIVKLE® M8 to M16	RIVKLE® Plusnut M8 to M10
Maximum stroke	8 mm	14 mm
Maximum setting force	40 KN	25 KN
Operating air pressure	5,5 bar min to 7 max	5,5 bar min to 7 max
Weight without tooling	3,4 kg	3,1 kg
Air consumption	12L max per cycle	12L max per cycle
Noise level	70 dB (A)	70 dB (A)
Cycle time	4,6 s	4,5 s
Dimensions (mm)	Height: 368 - width: 313	Height: 367 - width: 276

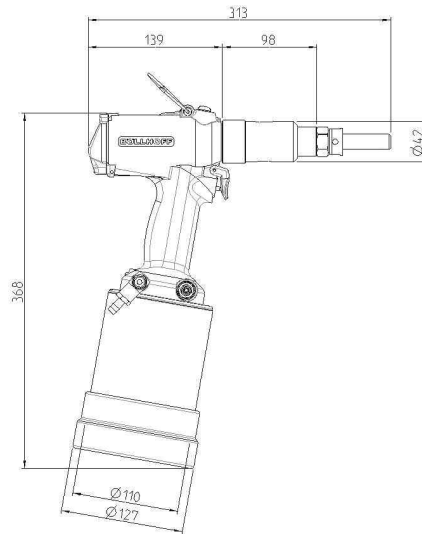



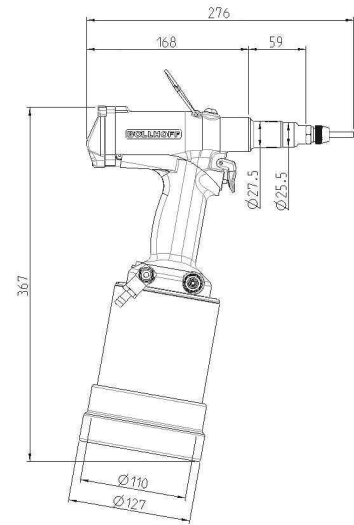

RIVKLE® P3007



RIVKLE® P3007 PN

Tooling for setting

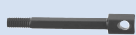
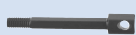
RIVKLE® P3007		Cod.	ø RIVKLE®				
			M8	M10	M12	M14	M16
Mandrel		236 159 XX 020	08	10	12	14	16
Anvil		236 159 XX 030	08	10	12	14	16

RIVKLE® P3007 PN		ø RIVKLE® PN	
		M8	M10
Mandrel		236 913 08 101	236 113 10 020
Anvil		236 913 08 087	236 913 10 010

MeFaCo Intl. bvba
 Industrieweg 2, B-9200 Dendermonde Belgium
 Tel.: +32 (0)52 203923 Fax : +32 (0)52 219524
 Web: <https://www.mefaco-intl.com>
 E-mail: info@mefaco-intl.com